

314D ALL SS PANEL MOUNT

Our '300' series gauge line is a high quality line of all stainless gauges. Hermetically sealing the gauge prevents dust, dirt or other contaminants from entering the case of the gauge and attacking the movement or internals of the gauge. Keeping out such contaminants prolongs the life of the gauge.

This gauge has been specifically designed with original equipment manufacturers in mind. It is typically used on chemical or food processing applications as well as any commercial or industrial application where stainless steel components are necessary.

SPECIFICATIONS:

- Front Flange Panel Mount Design
- Dial Sizes: 2 1/2" or 4"
- Connection Sizes: 1/4" MNPT (1/2" Available)
- Stainless Steel Case
- Stainless Steel Removeable Bezel
- Stainless Steel Internals & Connection
- 316SS Bourdon Tube
- Dry but Fillable
- Accuracy : 2 1/2" Dial = 1.5 % Full Scale
4" Dial = 1 % Full Scale
- Single Scale: PSI (Dual Scale available)
- Ambient temperature: FILLED: 30°F to 160°F
DRY: -30°F to 180°F



RANGE	CODE	Major In	Minor In
30/0/VAC	A	5	0.5
30/0/15	CB	5	0.5
30/0/30	CC	10	1
30/0/60	CD	10	1
30/0/100	CE	20	2
30/0/150	CF	20	2
30/0/300	CH	50	10
0/15	B	2	0.2
0/30	C	5	0.5
0/60	D	10	1
0/100	E	10	1
0/160	F	20	2
0/200	G	20	2
0/300	H	30	5
0/400	I	50	5
0/600	K	100	10
0/1000	M	200	20
0/1500	N	300	25
0/2000	O	200	20
0/3000	P	500	50
0/5000	R	500	50
0/10,000	U	1000	100
0/15,000	V	3000	250

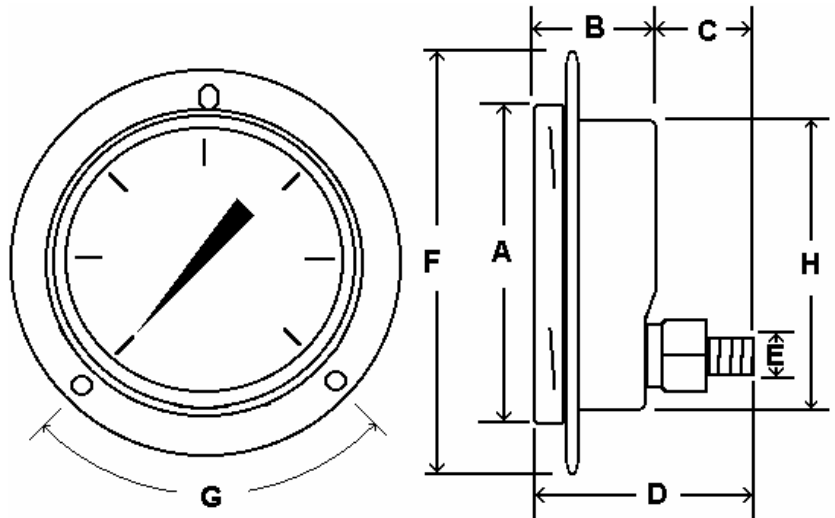

		A	B	C	D	E	F	H
2 1/2" Dial	In	2.71	1.23	1.00	2.23	1/4" NPT	3.45	2.45
	MM	68.8	31.3	25.4	56.7		87.6	62.2
4" Dial	In	4.36	1.73	1.34	3.07	1/4" NPT	5.22	3.84
	MM	111	44	34	78		132	97