

## STANDARD SPECIFICATIONS:

- DIAL:** 4 1/2" Diameter
- CASE:** Phenolic-Solid Front/Blow-Out Back
- LENS:** Plastic Shatterproof (Safety Glass Avail)
- POINTER:** Micro-Adjustable
- BOURDON TUBE:** 316 Stainless Steel
- SOCKET :** 316 Stainless Steel
- MOVEMENT:** 304 SS
- ACCURACY:** 0.5 % Full Scale



## STANDARD FEATURES

- \*Overload and Underload Stops
- \*Hermetically Sealed / Weather Proof
- \*Liquid Fillable / No Kit Required

## Ranges and Dimensions:

RANGE	FIGURES	MINOR
30"-0 hg vac	5"	0.2"
30"-0-15	10" & 5 psi	1" & 0.5 psi
30"-0-30	10" & 5 psi	1" & 0.5 psi
30"-0-60	10" & 10 psi	2" & 1 psi
30"-0-100	10" & 20 psi	2" & 1 psi
30"-0-150	10" & 30 psi	5" & 2 psi
30"-0-200	10" & 50 psi	5" & 2 psi
30"-0-300	10" & 50 psi	10" & 5 psi
30"-0-600	10" & 100 psi	10" & 10 psi
0-15 psi	3 psi	0.2 psi
0-30 psi	5 psi	0.2 psi
0-60 psi	5 psi	0.5 psi
0-100 psi	10 psi	1 psi
0-160 psi	20 psi	1 psi
0-200 psi	20 psi	2 psi
0-300 psi	50 psi	2 psi
0-400 psi	50 psi	2 psi
0-600 psi	50 psi	5 psi
0-800 psi	100 psi	5 psi
0-1000 psi	100 psi	10 psi
0-1500 psi	250 psi	10 psi
0-2000 psi	200 psi	20 psi
0-3000 psi	500 psi	20 psi
0-5000 psi	1,000 psi	50 psi
0-10,000 psi	1,000 psi	100 psi
0-15,000 psi	2,500 psi	100 psi
0-20,000 psi	2,000 psi	200 psi

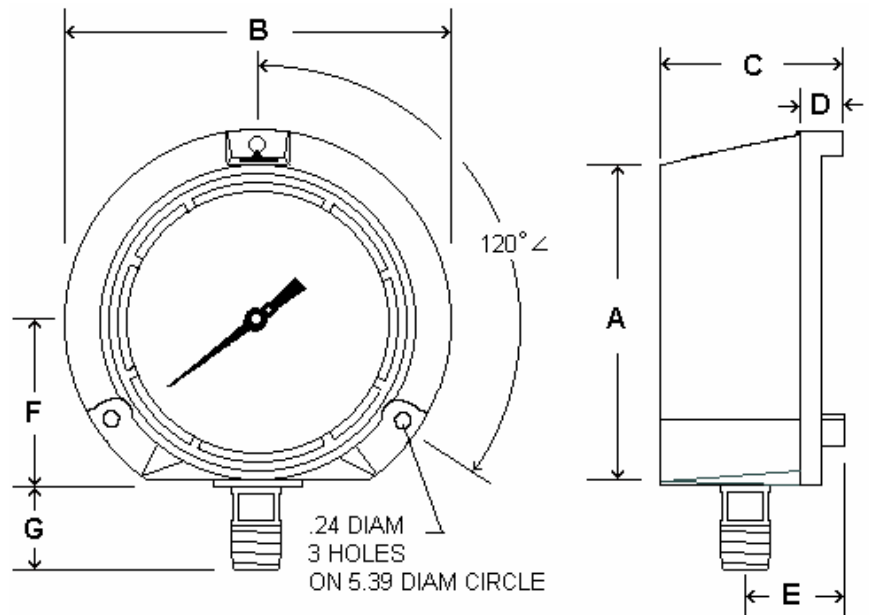

	A	B	C	D	E	F	G	NPT
INCH	5.07	5.91	3.03	.91	1.38	2.56	1.38	1/2" or
MM	129	150	77	23	35	65	35	1/4"