

HABONIM

73P, 74P, 77P & 78P Series

Installation, Operating & Maintenance

Full Port Flanged Ball Valves

Series Included:

73P, AF73P, 74P, AF74P
77P, AF77P, 78P, AF78P

Sizes Included:

1/2" - 8" (DN15 - DN200)

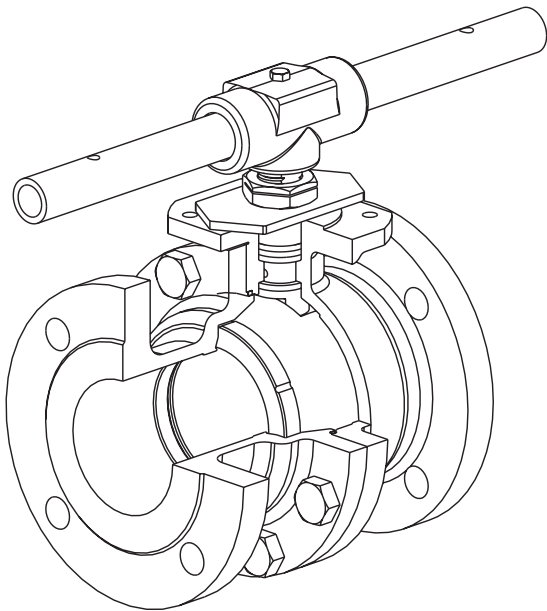

1. GENERAL

This Installation, Operating & Maintenance manual covers the instructions required for safe use of Habonim flanged ball valves type 73P/74P and 77P/78P series. The manual relates to ANSI and DIN full bore flanged ball valves. Before using a valve, read the entire IOM carefully and make sure you understand everything.

WARNINGS & SAFETY INSTRUCTIONS

Habonim cannot anticipate all of the situations a user may encounter while installing and using Habonim valves. The user **MUST** know and follow all applicable industry specifications on the safe installation and use of these valves. Misapplication of the product may result in injuries or property damage. Refer to Habonim product catalogues, product brochures and installation, operating and maintenance manuals for additional product safety information or contact Habonim.

1. Keep hands and objects away from the valve ports at all times. Actuated valves could be accidentally operated, resulting in serious injury or valve damage.
2. Before removing a valve from the line always make sure the line has been depressurized and drained. Cycle the valve a few times to relieve any pressure that could be trapped in the body cavity.
3. Utmost caution must be taken when handling a valve that has toxic, corrosive, flammable or a contaminant nature media flowing through its pipeline. The following safety precautions are recommended when dismantling valves with hazardous media:
 - a. Wear eye shield, protective headgear, clothing, gloves and footwear.
 - b. Have available running water.
 - c. Have a suitable fire extinguisher when media is flammable.
4. Do not try to operate a valve that exhibits any sign of leakage. Isolate the valve and either repair or replace it.
5. Do not use or substitute non Habonim components or parts in Habonim valves and assemblies.



Kfar Hanassi, Upper Galilee 12305 Israel
Tel: 972 - 4 - 6914911
Fax: 972 - 4 - 6914902
E-Mail: habonim@habonim.co.il
www.habonim.com

DEDICATED TO INNOVATION

2. LIMITATIONS

The correct selection of materials of construction, seats and seals, internal valve components and pressure/temperature ratings determines the safe use of the valves and the particular performance requirements for the application. This information can be found on the nameplate welded to the valve body.

The combined **corrosion** and **erosion** allowance for the valve body wall thickness is 1 mm. When this allowance has gone, the valve should no longer be used. Inspect the valve wall thickness every time the valve is maintained. Refer to Habonim Corrosion Data Chart T-614 to determine the corrosion rate for your application.

As the extent of applications these valves can be used in is large, it does not make it possible to cover all installation and maintenance instructions to service the valves. It is the owners responsibility to use the valves as recommended and in accordance with the pressure and temperature limits as stated in this manual. Where in doubt, please consult with Habonim. Any unstable fluid or gas should be identified by its manufacturer and must not be used with Habonim valves.

CAUTION:

The valves should be used in a well designed, adequately protected system to **ensure that external and internal pressure and temperature limits are not exceeded**. The valve body rating can be higher than the seat rating. Valve surface temperature may become extremely hot or cold due to ambient or operating conditions. Prevent any type of direct contact with the valve that may harm the workers. Wear protective gloves.

The valves should be used in a well designed, adequately supported piping system such that it will not be subjected to undue forces and moments during service. Avoid shock loads (water hammer). The valves are not designed to operate during or after earthquakes or under fatigue conditions. It is the responsibility of the owner to determine if fatigue conditions exist.

Only graphite stem seals are allowed in ATEX certified valves. Refer to certificate BSi 06ATEX9506565X for special conditions for safe use.

When gasketing always ensure multiple ground paths across gaskets. i.e. < 1Ω across total gasket.

Do not allow dust layers to build up on the equipment. The process fluid temperature shall not exceed the ignition temperature of the dust.

3. STORAGE

Prior to storage, inspect the valve for shipping damage. Keep all protective packaging and flange covers attached to the valves during storage. It is recommended to keep the valves in a clean and dry environment until ready for use.

Carbon Steel valves have a "black oxide" and oil dipped finish. This nontoxic process is performed to retard rusting during storage. It is not a substitute for paint or other means of protective coating to be applied to the valve once installed.

Stainless steel valves have their natural finish and do not need any additional protection once installed.

4. OPERATING INSTRUCTIONS

Habonim valves provide tight shut off when used under normal conditions and in accordance with Habonim's published pressure/temperature chart. Consult with Habonim for the proper seat material selection. Valve operation works by operating the valve handle 90° turn anti-clockwise to open, and 90° turn clockwise to close. On manually operated valves the valve is open when the handle or stem flats are parallel with the pipeline and closed when the handle or stem flats are perpendicular to the pipeline. Valves above 2" have a square headed shaft with a groove on the top that shows the ball position.

All standard valves are bidirectional and as such, can be installed for flow in either direction. Valves which are unidirectional will have a flow direction arrow welded to the body and separate assembly instructions. Valve sizes 1/2" to 1" are one piece and have an insert. It is recommended to install these valves with the insert facing to the upstream direction. If a shut-off valve is installed for end of line service, it must be ensured that it is closed with a blind end connection and the valve is secured against being opened unintentionally.

WARNING: Never look into the valve bore while the valve is in a flowline. Pressure and fluids could escape from the valve causing bodily injury.

A silicone-based lubricant is applied to assist valve break in. The lubricant, if unacceptable, may be removed by a solvent wash.

To prevent leakage malfunctions resulting from internal wear or seal degradation, the user must establish a preventive maintenance and inspection program. This program must include:

- a. Inspection of parts to detect loss of wall thickness which may result in decreased pressure capacity.
- b. Routine replacement of seals and inspection for proper operation.

Valve operating torques as published in the Habonim literature are the normal expected maximum break-away torques. These torques have been confirmed by laboratory testing of each valve under controlled conditions. Highly viscous or abrasive media, frequency of operation and temperature fluctuations could cause an increase in valve torque.

5. INSTALLATION

The installation procedure for ball valves is critical to ensuring both long life and satisfactory performance. Valves stored on site awaiting installation should be kept in their original packing, in dry conditions, where damage will not occur. Before carrying out the installation, it is important to follow the basic procedures described below:

5.1 General

- 5.1.1 Carefully unpack the valve and check valve nameplate for identification of materials (see **Figure 1**).
- 5.1.2 Remove any special materials, which were used for packing.
- 5.1.3 Check the valve for any marks indicating flow direction. Appropriate care must be taken, to install the valve for proper flow orientation.
- 5.1.4 Inspect the valve interior through the end ports to determine it is clean and free from foreign matter.
- 5.1.5 Cycle the valve and inspect any functionally significant features.
- 5.1.6 Read all the literature and note any special warning tags or plates attached to the valve.

- 5.1.7 Before installation of manually operated valves, check to insure the ball is in the fully open position in order to prevent possible damage to the ball and seats. Fail-to-close actuated valves should be operated to the open position for inspection. The valve performance depends on its original conditions.
- 5.1.8 Use the correct bolt material and size that suits the valve flanges.
- 5.1.9 Use the appropriate gasket material and structure for the application.
- 5.2 Flanged Valves**
- 5.2.1 Before installing the valves, make sure the flanges on the mating pipe are free from excessive grit, dirt or burrs.
- 5.2.2 The mating flanges must be aligned and parallel with the correct distance to allow the valve face-to-face dimension and gaskets to fit between.
- 5.2.3 Insert the valve between the mating flanges. If tilting or levering of the flanges is required, avoid harming the sealing surfaces of the flanges.
- 5.2.4 Align the valve and mating flanges and insert at least 2 bolts at the lowest side of the flange to support the gaskets.
- 5.2.5 Insert the gaskets between the flanges. Insert the remaining bolts.
- 5.2.6 Before tightening the bolts, make sure the gaskets are aligned with the raised face of the mating flanges.
- 5.2.7 Tighten the flange bolts according to the gasket manufacturer's recommended instructions or to the torque figures shown in **(table 3)** using the tightening patterns in **(figure 2)**.
- 5.2.8 It is recommended to use ring spanners to tighten and support the bolts and nuts.
- 5.2.9 Before flushing the line, be sure the valves are in the fully open position. Fail-to-close actuated valves should be operated to the open position for flushing.
- 5.2.10 Before pressure testing the valves, bring the valves to the half-open position to ensure pressure reaches the stem seals and to avoid unnecessary loading of the seats. Fail-to-close actuated valves should be brought to the half-open position.

6. MAINTENANCE

HABONIM valves have a long and trouble free life, and maintenance is seldom required. When maintenance is necessary, valves can be refurbished on site.

To extend valve performance and reduce possible plant problems, the following procedures should be followed:

- 6.1 If leakage at the stem area is noted, it is recommended to tighten the gland nut about 1/6-turn as a routine maintenance procedure. This will compensate for any wear or settling of the gland packing.
- 6.2 **Caution:** Excessive tightening of the stem nut can result in accelerated seal wear and high valve operating torque.
- 6.3 If the valve is removed from the line and disassembled, replacement of all seats and seals is recommended using the appropriate Habonim Repair kit. Examine all metallic sealing surfaces such as ball and stem or the body and insert mating surfaces that contact the seats for wear, corrosion or damage.
- 6.4 Only Habonim's authorized spare parts should be used. Repair kits from Habonim flanged reduce bore valves consist of the following:
- 2 x soft seat rings
 - 1 x body seal
 - 1 x stem thrust ring
 - 2 or 3 x gland packing (depends on valve size or seal material)
- 6.5 In addition to repair kits, other spare parts available from Habonim are: valve balls, stems, glands, bolts, screws and nuts. Should additional parts be required, it is recommended that the complete valve be replaced.
- 6.6 When ordering repair kits, please provide the valve size and full figure number code and series.

7. DISASSEMBLY

The following instructions are for disassembly of flanged valves sizes 1/2" to 1" (which are 1-piece construction).

- 7.1 Cycle the valve with the line pressure fully relieved before attempting to remove the valve from the pipeline, to insure pressure has also been discharged from the valve cavity.
- 7.2 Loosen all flange bolts. Before removing the valve, allow the fluid to drain from the valve ports.
- 7.3 Remove all but one flange bolt on either side of valve, so the valve body can swing away from its installed position and be brought out of the pipe line. Make sure there is no load on the flange before removing the remaining bolts and valve. If needed, use a lever to release the bolts.
- 7.4 Clamp the valve in a vice or connect the valve back flange to a fixture to support it before removing the valve insert.
- 7.5 Bring the valve to the closed position.
- 7.6 Remove the valve insert using a hexagon shape key or a special tool. It may be necessary to use a pipe extension for the tool.
- 7.7 Remove the seat and the body seal. Be careful not to damage the sealing surfaces.
- 7.8 From the other valve end port tap the ball out using a wooden or plastic mallet. Support the ball to prevent it from falling out of the body. Set the ball aside in clean secure area for reuse.
- 7.9 Remove the wrench nut, serrated washer, handle, locking clip, gland nut, disk springs and gland. Place all components removed, in clean secure area.
- 7.10 Push the stem down into the body and remove it. Discard the stem thrust ring and packing, care taken not to scratch or nick the packing bore area of the body. Clean the stem and packing bore area.
- 7.11 Using a tool with a hook, pull out the second seat from the valve cavity, taking care not to damage the sealing surfaces of the valve.

8. ASSEMBLY

The following instructions are for assembly of flanged valves sizes 1/2" to 1".

- 8.1 Clean the valve entrance thread and the insert thread. Smear

- an anti-seize lubricant on the insert thread and screw it to the valve body until it reaches the thread end. Do not tighten hard. At this point the insert should be 0.2 mm above the valve raised face. Mark a straight line across the valve and insert to indicate the final screwed position for use later. Remove the insert from the valve body.
- 8.2 Insert one new seat ring into the valve cavity with its round profile facing up.
 - 8.3 Lubricate the new stem thrust ring with appropriate lubricant (Molycote 33 - thin smear).
 - 8.4 Place the stem thrust ring on the stem and insert the stem horizontally into the center body with the threaded side first and carefully guide it up through the stem bore.
 - 8.5 Holding the stem up insert the new packing over the stem and into the stem bore. Place the gland and two disk springs onto the stem. The first spring concave side down and the second spring concave side up.
 - 8.6 Thread the gland nut onto the stem. Tighten the gland nut to the torque figures (**table 1**).
 - 8.7 Place the locking clip on the gland nut by adjusting the orientation of the nut (in the clockwise direction).
 - 8.8 For manual valves, place the handle, serrated washer and thread the wrench nut on the stem. Holding the handle tighten the wrench nut tight. For actuated valves, place the serrated washer and thread the wrench nut on the stem. Holding the top of the stem tighten the wrench nut tight.
 - 8.9 Bring the valve stem to the closed position and insert the ball in the valve cavity until the stem tang is engaged to the ball slot and the ball is nested in the seat.
 - 8.10 Place the new body seal and seat ring (with its round profile facing the ball) into the valve body.
 - 8.11 Screw back the insert using the proper tool and tighten to its preset mark as described in item 8.1 of this section. It is acceptable to be up to 20mm to the left of the body mark.
 - 8.12 Refer to the Installation Instructions in section 5 of this manual to complete the valve assembly to the line.
 - 8.13 Leave the valve in the open position for flushing the line.

9. DISASSEMBLY

The following instructions are for disassembly of flanged valves sizes 1 1/2" to 6" (which are 2-piece construction).

- 9.1 Follow steps 7.1 to 7.5 from previous section.
- 9.2 Loosen the valve body bolts and remove the end cap. Lay the end cap on the flange side and remove the seat from its place.
- 9.3 Remove the ball and body seal from the body. Take care not to damage the sealing surfaces of the body or end cap. Set the ball aside in clean secure area for reuse.
- 9.4 Pull out the second seat from the body cavity, taking care not to damage the sealing surfaces of the valve.
- 9.5 Remove the wrench bolt, wrench pipe, wrench head, gland nut, indicator stop plate and gland. Place all components removed, in clean secure area.

- 9.6 Push the stem down into the body and remove it. Discard the stem thrust ring and gland packing, care taken not to scratch or nick the packing bore area of the body. Clean the stem and packing bore area. There is no need to remove the stem location ring.

10. ASSEMBLY

The following instructions are for assembly of flanged valves sizes 1 1/2" to 6".

- 10.1 Insert one new seat ring into the end cap with its round profile facing up and put it aside.
- 10.2 Lubricate the new stem thrust ring with appropriate lubricant (Molycote 33 - thin smear).
- 10.3 Place the stem thrust ring on the stem and insert the stem horizontally into the center body with the threaded side first and carefully guide it up through the stem bore.
- 10.4 Holding the stem up insert the new packing over the stem and into the stem bore. Place the gland and indicator stop plate onto the stem.
- 10.5 Thread the gland nut onto the stem. Tighten the gland nut to the torque figures (**table 1**).
- 10.6 Place the wrench head on the stem square so the pipe will be parallel to the groove marked on its head. Insert the pipe in the wrench head and screw the wrench bolt. Turn the wrench to the closed position.
- 10.7 Actuated valves have a special stem assembly supplied with the mounting kits. On valve sizes 3" and above, place two disk springs above the gland. The first spring concave side down and the second spring concave side up. Insert the stem location ring and tab washer and fasten the non-slotted nut to the required torque. To lock the nut, bend the tab washer to the nut flats. Refer to illustration of "Stem arrangement for actuated valves on page 7.
- 10.8 Secure the body with its open side facing up and insert the second seat ring into its housing with its round profile facing up.
- 10.9 Insert the ball in the body cavity until the stem tang is engaged to the ball slot and the ball is nested in the seat.
- 10.10 Place the new body seal into the valve body.
- 10.11 Holding the end cap and the seat together from the inside of the passage, carefully place them on the valve body making sure not to damage the ball or body seal.
- 10.12 Laying the end cap and its seat on the ball, align it to the body bolt holes, making sure that the body flange and end cap flange are correctly oriented.
- 10.13 Insert the body bolts and tighten them evenly to the torque figures in (**table 2**) using a proper tool. With stainless steel bolts use anti-galling lubricant.
- 10.14 Refer to the Installation Instructions in **section 5** of this manual to complete the valve assembly to the line.
- 10.15 Leave the valve in the open position for flushing the line.

FIGURE 1
Valve Marking and Labeling

All valves marking is on a nameplate which is spot welded to the valve body. Valves for the European market and above 1" carry the CE mark with the information required by the PED.

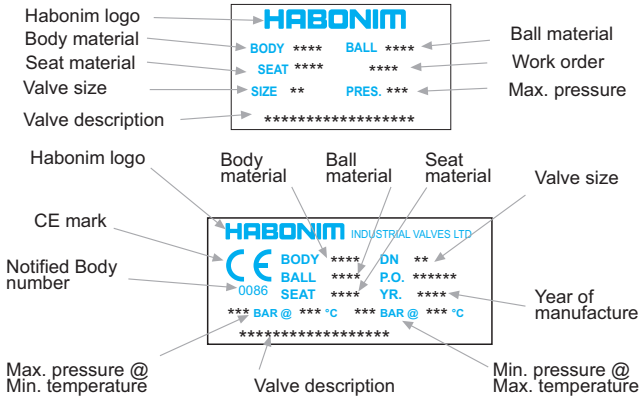

Valve ATEX Marking and Description

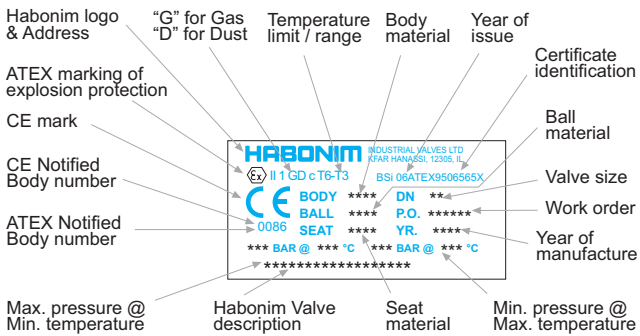

* **Note:** T3-T6 means that the temperature classification is entirely dependant upon the process & ambient temperature.

TABLE 1
Gland Nut Tightening Torque

Valve Size (in)	Valve Size (DN)	Nut Thread	* PTFE Seals		* * Graphite Seals	
			Nm	in.lb	Nm	in.lb
1/2"	15	3/8"-24 UNF	4.0	35	4 - 6	35 - 53
3/4"	20	7/16"-20 UNF	9.0	80	9 - 11	80 - 97
1	25	7/16"-20 UNF	9.0	80	9 - 11	80 - 97
1 1/2"	40	9/16"-18 UNF	13.0	115	13 - 16	115 - 140
2"	50	9/16"-18 UNF	13.0	115	13 - 16	115 - 140
3"	80	1" - UNS	60.0	530	60 - 72	530 - 637
4"	100	1" - UNS	60.0	530	60 - 72	530 - 637
6"	150	1 1/2" - UNS	120.0	1060	120 - 145	1060-1280
8"	200	2" - 10 UNS	140.0	1240	140 - 155	1240 - 1372

* These torque figures are applicable on other stem seal materials such as glass filled PTFE, UHMWPE and TFM.

** Graphite stem seals must be torqued to the higher torque figure in the table, then cycled 6-10 times and re-torqued to the lower torque figure.

IMPORTANT:

An excessively tightened gland nut can cause excessive packing wear and increase stem torque.

TABLE 2
Body Bolt Tightening Torque

The following table provides body bolt torque values to connect the end cap for valve sizes 1 1/2" to 6".

Valve Size (in)	Valve Size (DN)	Body Bolt Size	Number of Bolts	Tightening Torque (Nm)		Tightening Torque (Nm)	
				S/S	C/S	S/S	C/S
1 1/2"	40	M12	4	65	75	575	664
2"	50	M12	4	65	75	575	664
3"	80	M16	8	160	200	1,416	1,770
4"	100	M16	10	160	200	1,416	1,770
6"	150	M20	12	300	370	2,655	3,275
8"	200	M20	12	300	370	2,655	3,275

TABLE 3
Flange Bolt Tightening Torque

The following table provides flange bolt torque values and are used as guidelines only and are not rigid limits.

The torque values will be determined by the gasket type and the material of the gasket, bolt, flange and lubricant used. It is the responsibility of the user to determine all these parameters and use the correct values.

Valve Size (in)	Valve Size (DN)	ANSI 150		ANSI 300	
		Nm	in.lb	Nm	in.lb
1/2"	15	80	710	80	710
3/4"	20	80	710	140	1,240
1	25	80	710	140	1,240
2 1/2"	40	80	710	240	2,120
2"	50	140	1,240	140	1,240
3"	80	170	1,500	250	2,210
4"	100	170	1,500	250	2,210
6"	150	170	1,500	250	2,210
8"	200	170	1,500	270	2,390

IMPORTANT:

From the bolts point of view, the torque selected should be high enough to ensure adequate strain (stretch) in the bolt, but not so high as to cause the material to be taken beyond yield into the plastic response region.

If the initial bolt stress is too low the total amount of strain (stretch in the bolt) is low and under these circumstances any subsequent reduction in thickness of the gasket due to creep will quickly result in loss of bolt strain and subsequent leakage.

FIGURE 2
Flange Bolt Tightening Pattern

When installing the valves in-line, follow the bolt tightening patterns shown below, using the recommended torque figures for safe operation.

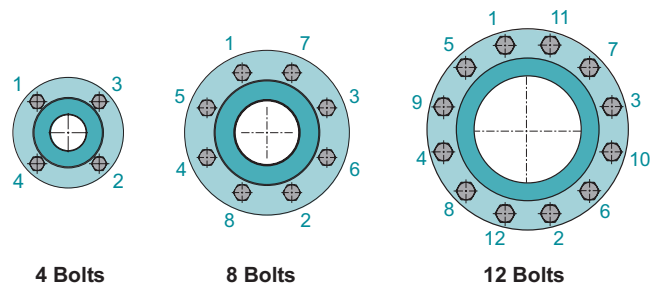

73/74P & 77/78P Series Valve

Sizes: 1/2" - 1"

Item	Description	Material Specifications
1	Body	Stainless St. ASTM A351 CF8M Carbon St. ASTM A 216 WCB
2	Insert	Stainless St. ASTM A351 CF8M Carbon St. ASTM A 216 WCB
3	Ball	Stainless St. AISI 316
4	Stem	Stainless St. AISI 316
5*	Seat Ring	Virgin PTFE
6*	Body Seal	Virgin PTFE
7*	Stem Thrust Seal	PTFE- 25% carbon filled
8	Stop pin	Stainless St. AISI 316
9*	Stem seal	PTFE- 25% carbon filled
10	Gland	Stainless St. 316
11	Disc spring	Stainless St. 17-7PH
12	Gland nut	Stainless St. AISI 316
13	Tab washer	Stainless St. AISI 316
14	Wrench	Stainless St. AISI 304 Carbon St. ZINC plated
15	Serrated washer	Stainless St. AISI 316
16	Wrench nut	Stainless St. AISI 316
17	Sleeve	Vinyl plastisol
18	Plunger spring	Stainless St. AISI 302
19	Anti static plunger	Stainless St. AISI 316

The materials above are for standard applications. Other materials are available.

* Standard items supplied in repair kits.

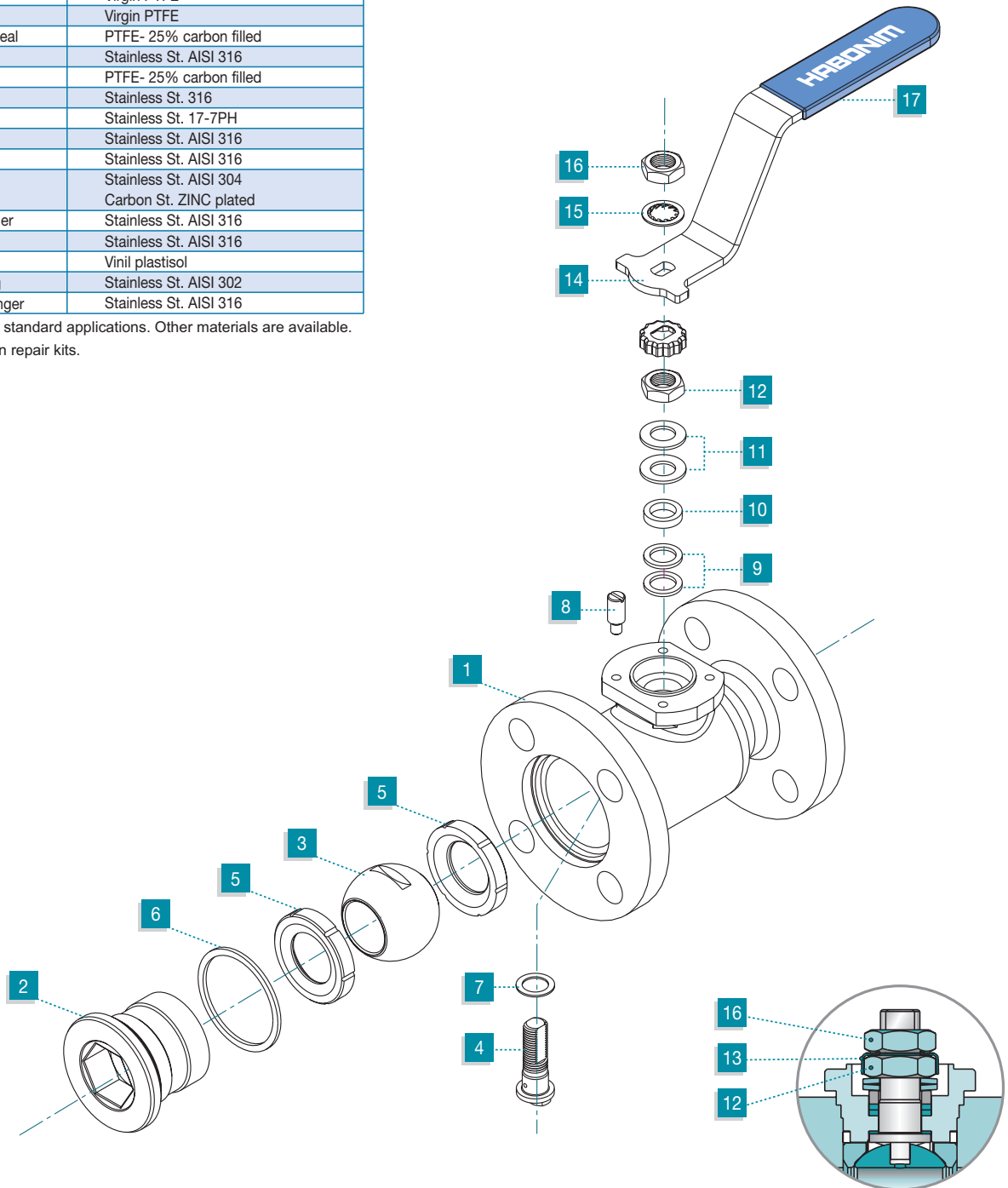

Stem arrangement for actuated valves.

Release the wrench nut **16** and serrated washer **15** and remove the wrench **14**. Refasten the nut **16** on the tab washer **13**. Valves 1/2" & 3/4" do require the wrench nut **16**.

Habonim reserves the right to change design features without prior notice.

PEEK® is a trademark of VICTREX.
VESPEL™ is a registered trademark of DuPont.

73/74P & 77/78P Series Valve

Sizes: 1 1/2" - 8"

Item	Description	Material Specifications
1	Body	Stainless St. ASTM A351 CF8M Carbon St. ASTM A 216 WCB
2	End cap	Stainless St. ASTM A351 CF8M Carbon St. ASTM A 216 WCB
3	Ball	Stainless St. AISI 316
4	Stem	Stainless St. AISI 316 or 17-4PH
5*	Seat Ring	Virgin PTFE
6*	Body Seal	Virgin PTFE
7*	Stem Thrust Seal	PTFE- 25% carbon filled
8	Stop pin	Stainless St. AISI 316
9*	Stem location ring	Stainless St. AISI 316
10	Gland packing	PTFE- 25% carbon filled
11	Gland	Stainless St. AISI 316
12	Indicator stop plate	Carbon St. ZINC plated
13	Gland nut	Carbon St. ZINC plated
14	Wrench	Malleable iron
15	Wrench handle	Tube SCH. 40 ZINC plated
16	Wrench bolt	Stainless St. AISI 304
17	Body connector Screw	Stainless St. AISI 304 Carbon St. ZINC plated
18	Plunger spring	Stainless St. AISI 302
19	Anti static plunger	Stainless St. AISI 316

The materials above are for standard applications. Other materials are available.

* Standard items supplied in repair kits.

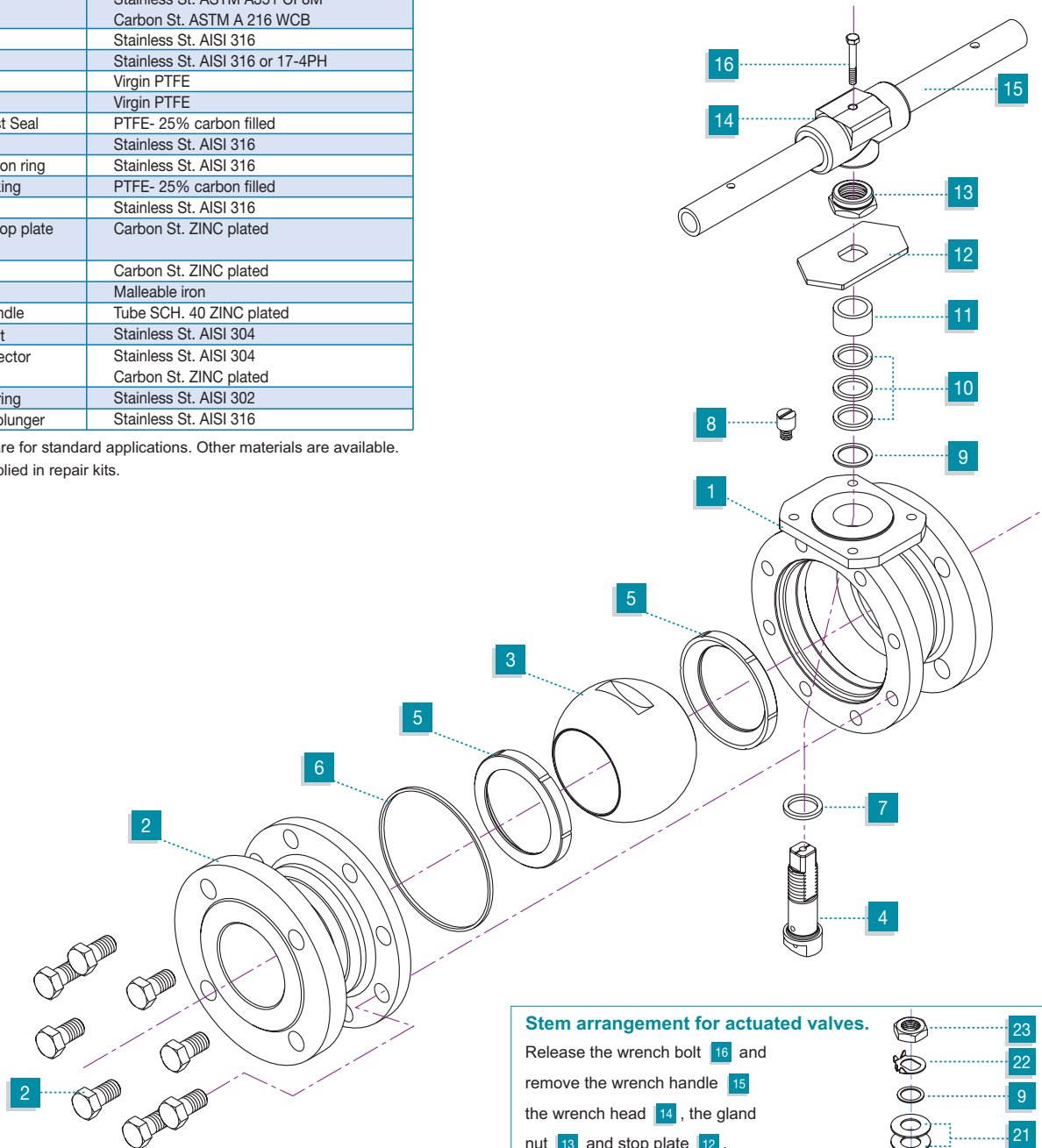

Stem arrangement for actuated valves.

Release the wrench bolt **16** and remove the wrench handle **15** the wrench head **14**, the gland nut **13** and stop plate **12**. Assemble the two disc springs **21**, stem location ring **9**, tab washer **22** and refasten the non-slotted gland nut **23**.

