

Instrumentation Manifold Valves



2-Valve Manifold

Kor-Lok 2-Valve Manifolds offer safety and reliability in a general purpose design. The simple 2-Valve configuration allows for easy block, bleed and calibration of a static pressure transmitter or gauge. Valves are available with either metal seats or replaceable soft seat inserts. Connections are 1/2" female NPT on all three ports.

Materials of Construction

No.	Description	Material
1	Handle	Stainless Steel
2	Handle Pin	17-4PH Stainless
3	Set Screw	
4	Packing Nut	Stainless Steel
5	Upper Gland	
6	Packing	PTFE/Grafoil
7	Lower Gland	316SS
8	Bonnet	
9a	Stem(Needle Tip)	
9b	Stem(Vee Tip)	Delrin
10	Soft Seat(Vee Tip)	
11	Cap Screw	Stainless Steel
12	Lock Plate	
13	Manifold Body	316SS

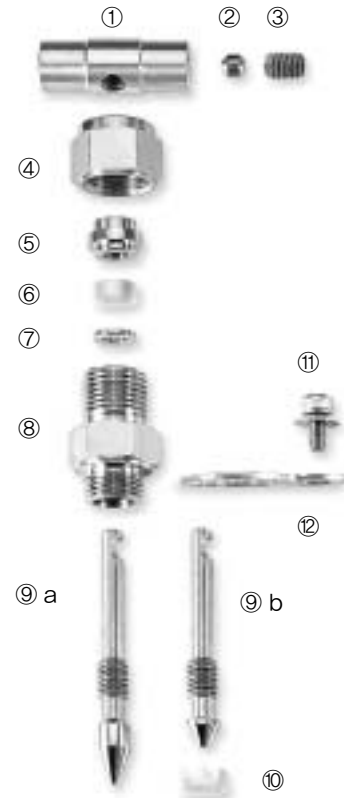

Manifold Valves • 2-Valve Manifold

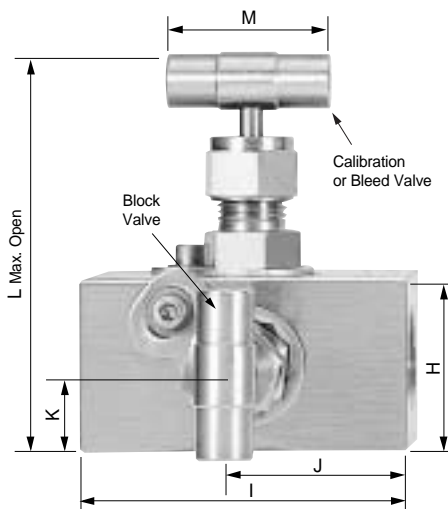
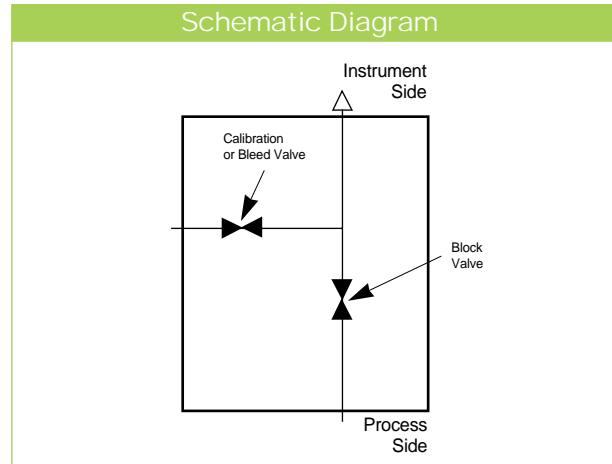
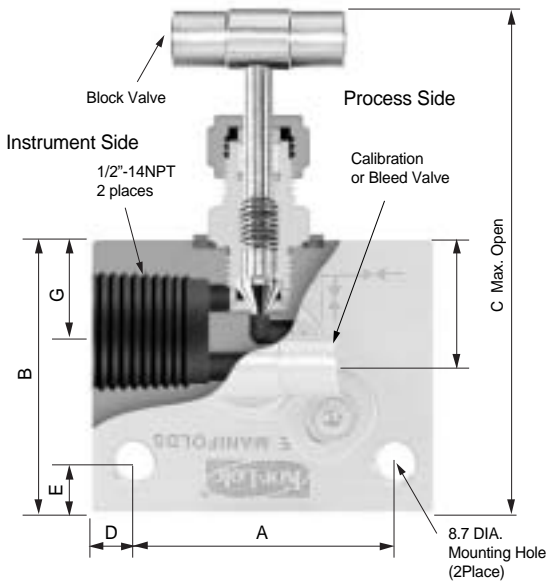

Table of Dimensions

Unit : mm

A	B	C(Open)	D	E	F	G	H	I	J	K	L(OPEN)	M
47.5	51.0	99.0	8.0	9.5	9.5	16.0	34	63.5	31.7	17.0	78.5	32.0

Technical Data for Proper Manifold Selection

Unit : mm

Stem Design	Port No.	Seat	Pressure Rating	Pressure Rating Max. Temperature	Packing
Needle Tip	2VMNT-8N-SS	316SS	413 bar from -54°C to 38°C (6000psi from -65°F to 100°F)	284bar @232°C (4130psi @450°F)	PTFE
	2VMNG-8N-SS			233 bar @454°C (3380psi @850°F)	Grafoil
Vee Tip	2VMD-8N-SS	Delrin		172 bar @121°C (2500psi @250°F)	PTFE

3-Valve Manifold

Kor-Lok Pipe to Pipe 3-Valve Manifold is a general purpose design for connection system impulse lines and transmitters. This manifold consists of two block valves and an equalizer valve. Connections are 1/2" Female NPT on 2-1/8" (54mm) centers for safety, an bonnet lock pin is standard.

Materials of Construction

No.	Description	Material
1	Handle	Stainless Steel
2	Handle Pin	17-4PH Stainless
3	Set Screw	
4	LocNut	Stainless Steel
5	Packing Bolt	316SS
6	Packing Support	Reinforced PTFE
7	Packing	PTFE/Grafoil
8	Bonnet	316SS
9a	Stem(Needle Tip)	
9b	Stem(Plug Tip)	
10	Seat(Plug Tip)	Delrin
11	Lock Plate	Stainless Steel
12	Cap Screw	
13	Manifold Body	316SS

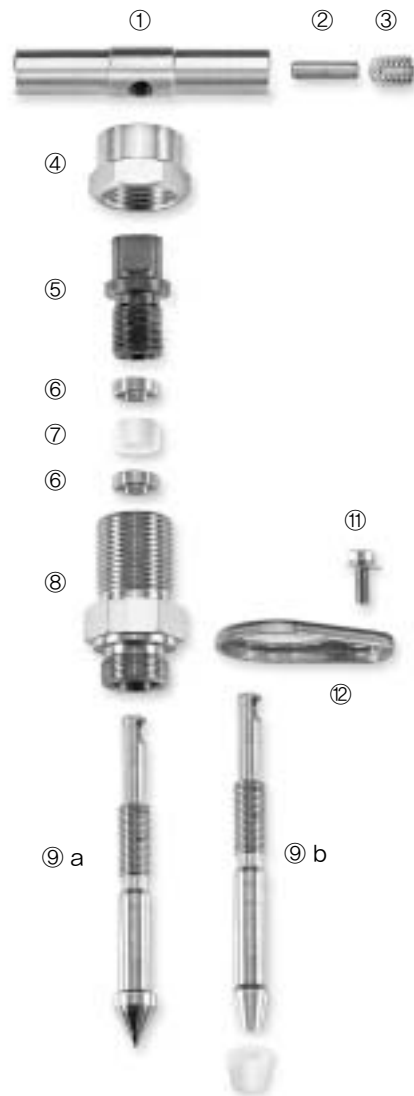

Manifold Valves • 3-Valve Manifold

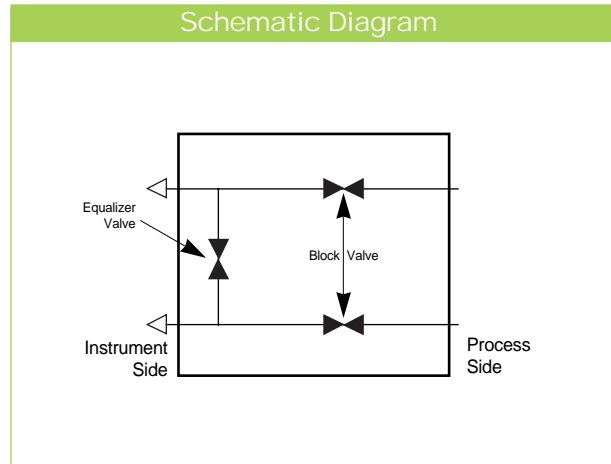
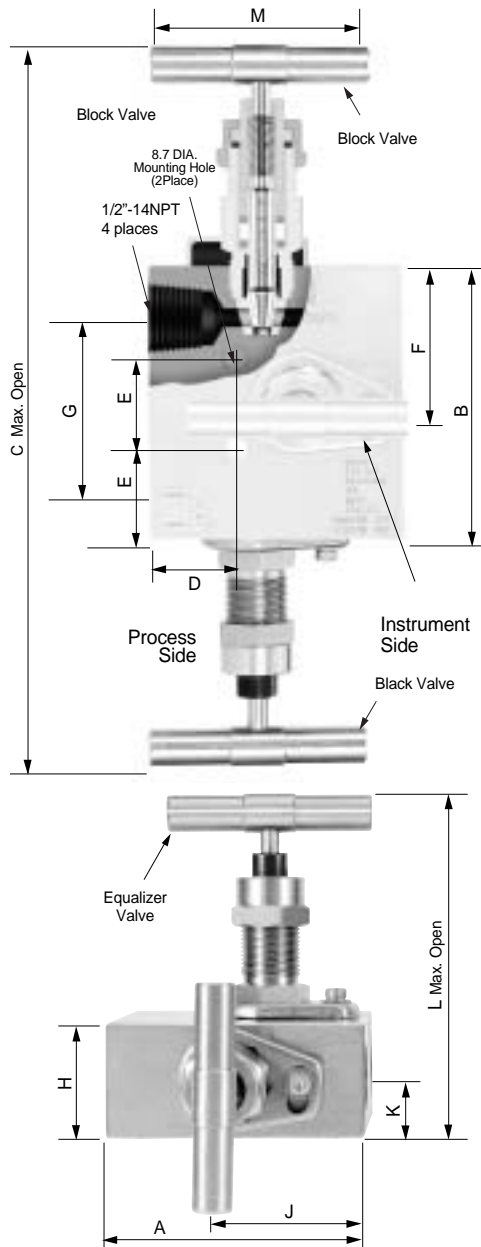

Table of Dimensions

Unit : mm

A	B	C(Open)	D	E	F	G	H	J	K	L(OPEN)	M
78.0	86.0	229.0	29	28.6	43	54	34	39.0	17.0	105.5	64.0

Technical Data for Proper Manifold Selection

Unit : mm

Stem Design	Part No.	Seat	Pressure Rating	Pressure Rating Max. Temperature	Packing
Needle Tip	3VMNT-8N-SS	316SS	413 bar from -54°C to 38°C (6000psi from -65°F to 100°F)	284bar @232°C (4130bar @450°F)	PTFE
	3VMNT-8N-FL-SS			118 bar @454°C (1715bar @1200°F)	Grafoil
3VMNG-8N-SS				68 bar @121°C (1000psi @250°F)	PTFE
Plug Tip	3VMVD-8N-SS	Delrin			
	3VMVD-8N-FL-SS				

5-Valve Manifold

5-Valve Manifold offer two mainline block valves and a double block and bleed valve for the equalizer line. The manifold is primarily intended for gas service and is used to connect differential pressure transmitters to system flow meters. Connections are 1/2"Female NPT on 2-1/8"(54mm) centers. Standard features include two 1/4"NPT static pressure connections on the instrument side and one 1/4"NPT vent connection from the bleed valve.



Equalizer & Bleed Valves

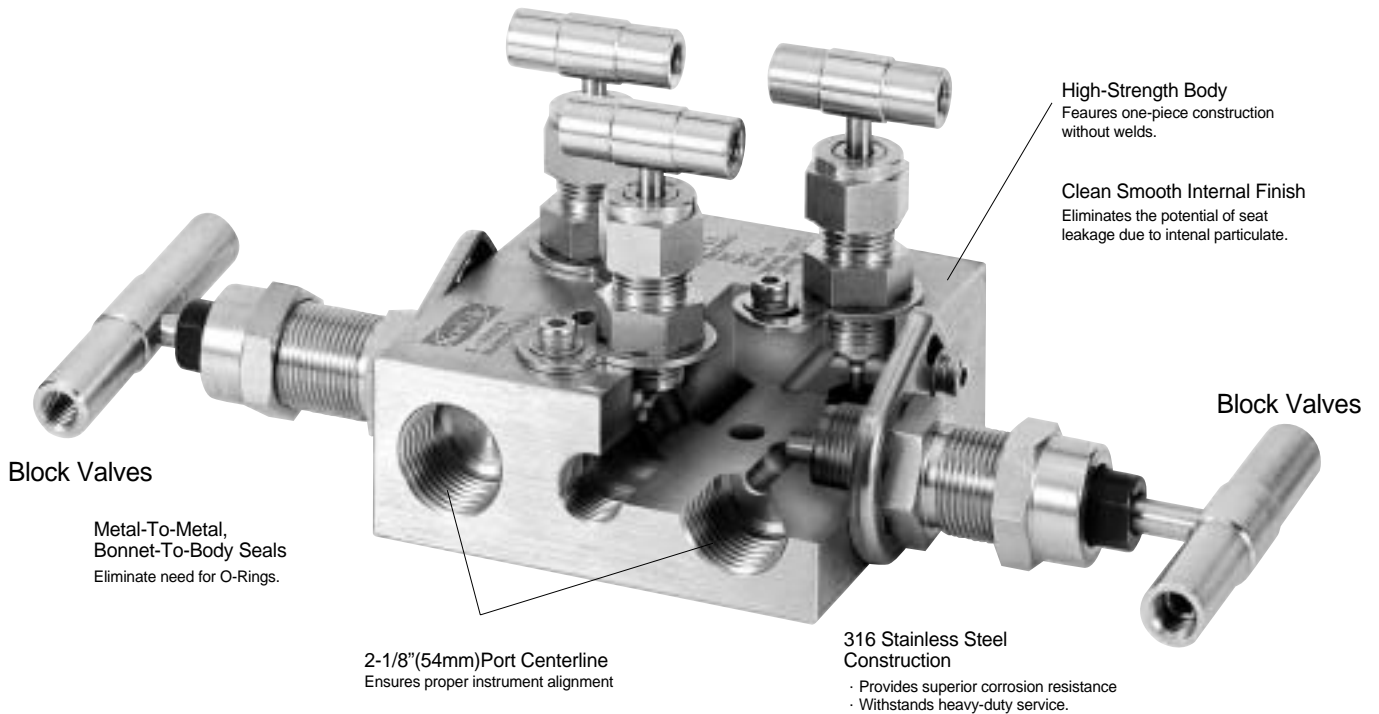

Materials of Constructons

The three Equalizer and Bleed valves have the same material construction as 2VMNT.
The two Block valves have the same material construction as 3VMNT.

Manifold Valves • 5-Valve Manifold

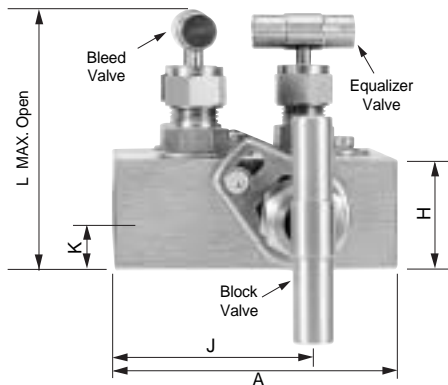
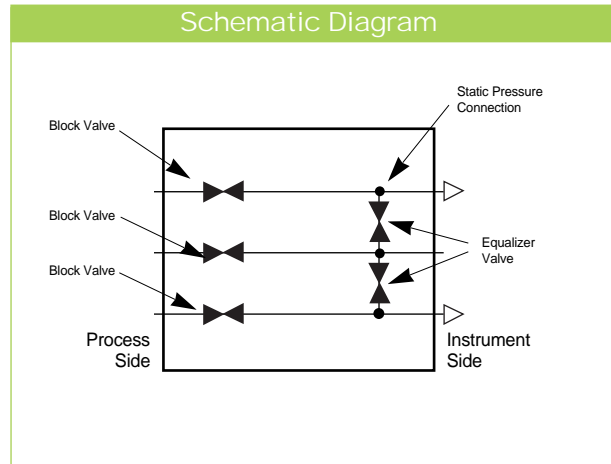
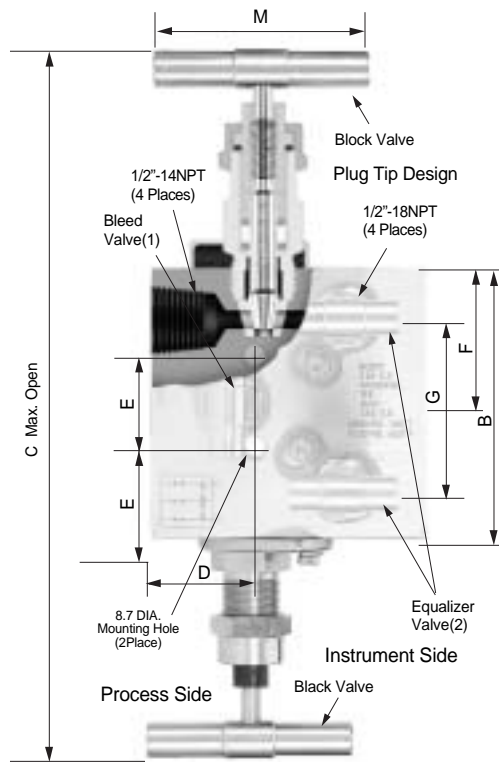

Table of Dimensions

Unit : mm

A	B	C(Open)	D	E	F	G	H	J	K	L(OPEN)	M
86.0	86.0	229.0	40.0	28.6	43	54	34	50	17	82	64.0

Technical Data for Proper Manifold Selection

Unit : mm

Stem Design	Ordering Number	Seat	Pressure Rating	Pressure Rating Max. Temperature	Packing
Needle Tip	5VMNT-8N-SS	316SS	413 bar from -54°C to 38°C (6000psi from -65°F to 100°F)	284 bar @232°C (4130psi @450°F)	PTFE
	5VMNG-8N-SS			118 bar @648°C (1715psi @1200°F)	Grafoil
Plug Tip	5VMVD-8N-SS 5VMVD-8N-FL-SS	Delrin		68 bar @121°C (1000psi @250°F)	PTFE

Features

- Pressure rating up to 6000psi(410 bar) at 38°C(100°F)
- Temperature rating up to 648°C(1200°F) with optional Grafoil packing One piece, high strength body construction for safety
- 316 stainless steel construction for superior corrosion resistance
- Stems features an non-rotating tip with an easily replaceable soft insert
- Bonnet lock pin prevents accidental valve disassembly
- Bonnet to body seals are metal to metal, No O-rings used
- Mounting holes provided for self-supporting application
- 2-1/8"(54mm) port centerline dimension for proper alignment
- Manifold feature a 4:1 safety factor

Testing

Standard Factory Test : Every valve is 100% factory tested with air and nitrogen at 1000psi(69bar) for shut off and at all seals. Each test is performed to a maximum allowable leak rate of 0.1scc/min.

Safe Valve Selection

When selecting a valve, the total system design must be considered to ensure safe, trouble-free performance. Valve function, materials compatibility, adequate ratings, proper installation, operation and maintenance are the responsibility of the system designer or user.

Manifold Selection Information

The pressure-temperature ratings are taken for ANSI B16.34 for standard class valves and are based on class 2500. Ratings for needle tip's design is based on specific seat materials.

How to Order

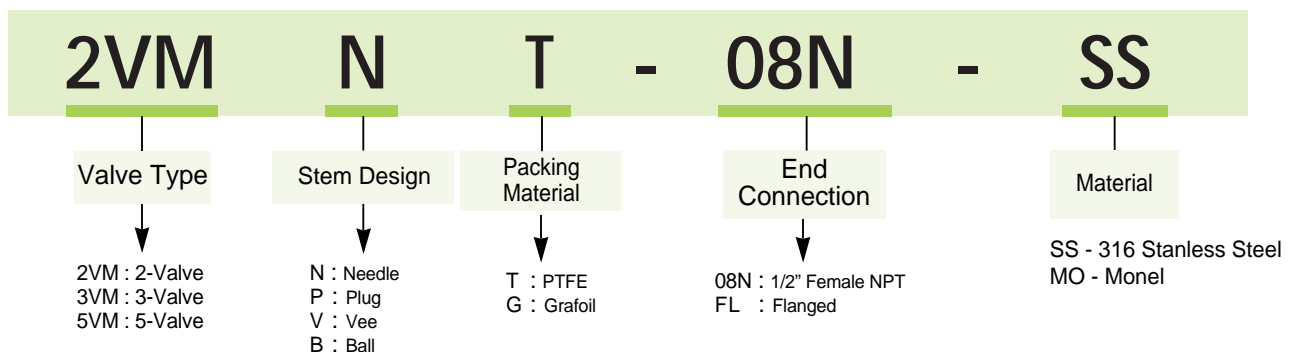

유니온금속공업(주)
UNION METAL INDUSTRIAL CO.,LTD.

Head Office and Factory
133 Block-1Lot, Namdong Industrial Complex.
704, Gojan-Dong, Namdong-Gu, Incheon, KOREA.
TEL:+82-32-821-6601 FAX:+82-32-821-6604
<http://www.unilok.com> E-mail : unilok@unilok.com
Master Distributor
Kor-Lok USA, LLC
15060 West Drive, Suite 100 Houston, TX 77053, USA
TEL:+1-281-437-8400 FAX:+1-281-437-8437
<http://www.korlokusa.com> E-mail:michelle@korlokusa.com