

Syphon (Pigtail)

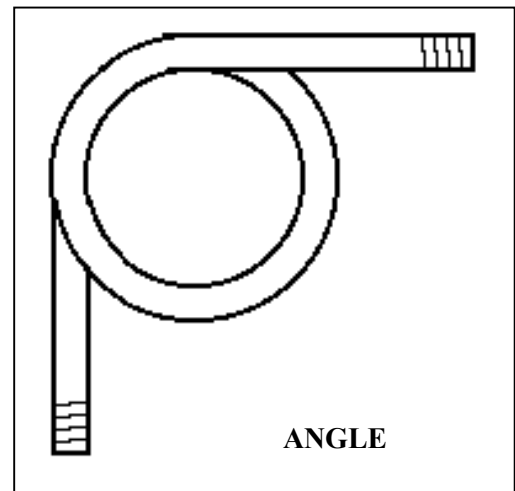

Pigtail Syphons are typically used to act as a cooling or warming leg for applications where the process temperature is higher or lower than the 'normal working temperature range' as specified by NIST B40.1 in relation to instrumentation. Temperature extremes can cause inaccuracy or shorten the life span of instruments not specifically designed for severe duty applications.

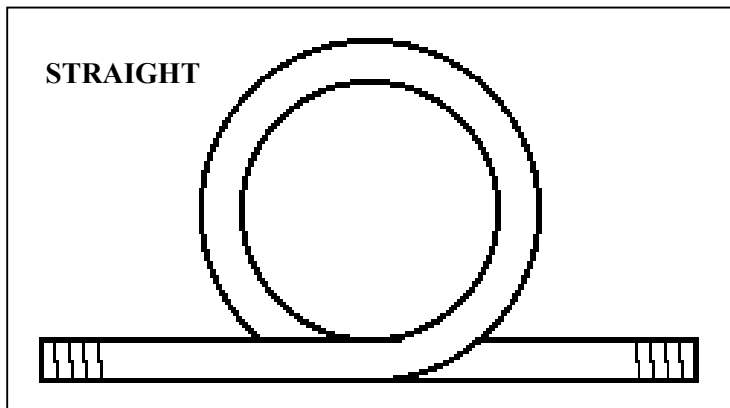

Part No.	Description	Pressure	Temperature
A03B	¼"NPT Brass Pigtail	250PSI	400°F
A031	¼"NPT Iron Pigtail, Schedule 40 Iron	500PSI	400°F
CPS4	¼"NPT Steel Pigtail, Schedule 80 Steel	1000PSI	850°F
CPS2	½"NPT Steel Pigtail	1000PSI	850°F
CPSS4	¼"NPT Stainless Steel Pigtail	2000PSI	1000°F
CPSS2	½"NPT Stainless Steel Pigtail	2000PSI	1000°F

For further information, please contact our engineering department at (888) 650-6923