

HABONIM

H27 & H23 Series

Installation, Operating & Maintenance

3-Piece Ball Valves

Series Included:

H27, HB27, AFH27, AFB27
H23, HB23

Sizes Included:

1/4" - 6" (DN6 - DN150)

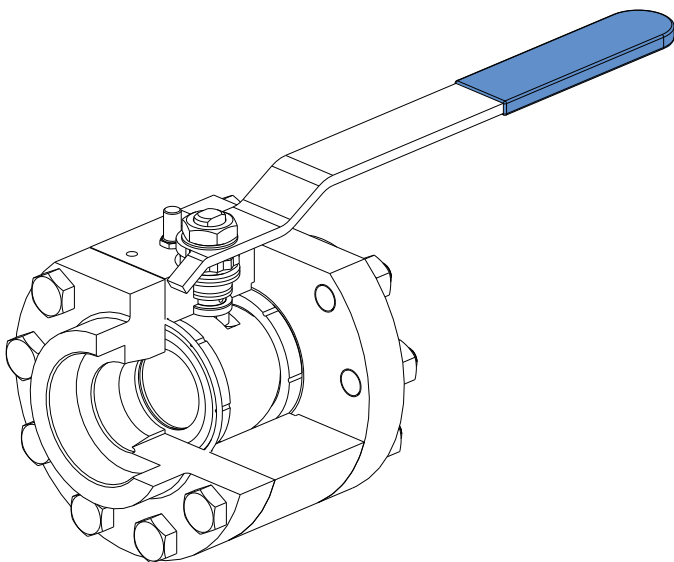

1. GENERAL

This Installation, Operating & Maintenance manual covers the instructions required for safe use of Habonim 3-piece High Pressure ball valves type H27 & H23 series. The manual relates to reduce bore, full bore and fire-safe valves. Before using a valve, read the entire IOM carefully and make sure you understand everything.

WARNINGS & SAFETY INSTRUCTIONS

Habonim cannot anticipate all of the situations a user may encounter while installing and using Habonim valves. The user **MUST** know and follow all applicable industry specifications on the safe installation and use of these valves. Misapplication of the product may result in injuries or property damage. Refer to Habonim product catalogues, product brochures and installation, operating and maintenance manuals for additional product safety information or contact Habonim.

1. Keep hands and objects away from the valve ports at all times. Actuated valves could be accidentally operated, resulting in serious injury or valve damage.
2. Before removing a valve from the line always make sure the line has been depressurized and drained. Cycle the valve a few times to relieve any pressure that could be trapped in the body cavity.
3. Utmost caution must be taken when handling a valve that has toxic, corrosive, flammable or a contaminant nature media flowing through its pipeline. The following safety precautions are recommended when dismantling valves with hazardous media:
 - a. Wear eye shield, protective headgear, clothing, gloves and footwear.
 - b. Have available running water.
 - c. Have a suitable fire extinguisher when media is flammable.
4. Do not try to operate a valve that exhibits any sign of leakage. Isolate the valve and either repair or replace it.
5. Do not use or substitute non Habonim components or parts in Habonim valves and assemblies.

2. LIMITATIONS

The correct selection of materials of construction, seats and seals, internal valve components and pressure/temperature ratings determines the safe use of the valves and the particular performance requirements for the application. This information can be found on the nameplate welded to the valve body.

CAUTION: It is not recommended to open the valves under full pressure rating as this can lead to severe damage. Always operate the valves at the rated pressures and temperatures as stated on the valve tag.

The combined **corrosion** and **erosion** allowance for the valve body wall thickness is 1 mm. When this allowance has gone, the valve should no longer be used. Inspect the valve wall thickness every time the valve is maintained. Refer to Habonim Corrosion Data Chart T-614 to determine the corrosion rate for your application.

As the extent of applications these valves can be used in is large, it does not make it possible to cover all installation and maintenance instructions to service the valves. It is the owners responsibility to use the valves as recommended and in accordance with the pressure and temperature limits as stated in this manual. Where in doubt, please consult with Habonim. Any unstable fluid or gas should be identified by its manufacturer and must not be used with Habonim valves.

CAUTION:

The valves should be used in a well designed, adequately protected system to **ensure that external and internal pressure and temperature limits are not exceeded**. The valve body rating can be higher than the seat rating. Valve surface temperature may become extremely hot or cold due to ambient or operating conditions. Prevent any type of direct contact with the valve that may harm the workers. Wear protective gloves.

The valves should be used in a well designed, adequately supported piping system such that it will not be subjected to undue forces and moments during service. Avoid shock loads (water hammer). The valves are not designed to operate during or after earthquakes or under fatigue conditions. It is the responsibility of the owner to determine if fatigue conditions exist.

3. STORAGE

Prior to storage, inspect the valve for shipping damage. Keep all protective packaging, flange covers and end caps attached to the valves during storage. It is recommended to keep the valves in a clean and dry environment until ready for use.

Carbon Steel valves have a "black oxide" and oil dipped finish. This nontoxic process is performed to retard rusting during storage. It is not a substitute for paint or other means of protective coating to be applied to the valve once installed.

Stainless steel valves have their natural finish and do not need any additional protection once installed.

4. OPERATING INSTRUCTIONS

Habonim Valves provide tight shut off when used under normal conditions and in accordance with Habonim's published pressure/temperature chart. If these valves are used in a partially open (throttled) position, seat life may

be reduced. Consult with Habonim for the proper seat material selection. Valve operation works by operating the valve handle 90° turn anti-clockwise to open, and 90° turn clockwise to close. On manually operated valves the valve is open when the handle or stem flats are parallel with the pipeline and closed when the handle or stem flats are perpendicular to the pipeline. All standard valves are bidirectional and as such, can be installed for flow in either direction. Valves which are unidirectional will have a flow direction arrow welded to the body and separate assembly instructions. A silicone-based lubricant is applied to assist valve break in. The lubricant, if unacceptable, may be removed by a solvent wash.

If a shut-off valve is installed for end of line service, it must be ensured that it is closed with a blind end connection and the valve is secured against being opened unintentionally.

WARNING: Never look into the valve bore while the valve is in a flowline. Pressure and fluids could escape from the valve causing bodily injury.

To prevent leakage, malfunctions resulting from internal wear or seal degradation, the user must establish a preventive maintenance and inspection program. This program must include:

- a. Inspection of parts to detect loss of wall thickness which may result in decreased pressure capacity.
- b. Routine replacement of seals and inspection for proper operation.

Valve operating torques as published in the Habonim literature are the normal expected maximum break-away torques. These torques have been confirmed by laboratory testing of each valve under controlled conditions. Highly viscous or abrasive media, frequency of operation and temperature fluctuations could cause an increase in valve torque.

5. INSTALLATION

The installation procedure for ball valves is critical to ensuring both long life and satisfactory performance. Valves stored on site awaiting installation should be kept in their original packing, in dry conditions, where damage will not occur. Before carrying out the installation, it is important to follow the basic procedures described below:

5.1 General

- 5.1.1 Carefully unpack the valve and check valve nameplate for identification of materials.
- 5.1.2 Remove any special materials, which were used for packing.
- 5.1.3 Check the valve for any marks indication flow direction. Appropriate care must be taken, to install the valve for proper flow orientation.
- 5.1.4 Inspect the valve interior through the end ports to determine it is clean and free from foreign matter.
- 5.1.5 Cycle the valve and inspect any functionally significant features.
- 5.1.6 Read all the literature and note any special warning tags or plates attached to the valve.
- 5.1.7 Before installation check to insure the ball is in the fully open position in order to prevent possible damage to the ball and seats. The valve performance depends on its original conditions. At any stage do not leave the valve in the partially open position.

5.2 Threaded End Valves

- 5.2.1 Valves with screwed ends should be treated as a single unit and should not be dismantled when installing to pipeline.
- 5.2.2 Before installing the valves, make sure that the threads on the mating pipe are free from excessive grit, dirt or burrs.
- 5.2.3 When tightening the valve, apply a pipe wrench or spanner to the end connector closest to the pipe being worked, using standard piping practices.
- 5.2.4 Use appropriate joining sealants material in correct quantities.
- 5.2.5 If "back-welding" is required on screwed valves, refer to the instructions for Weld End valves or to the "Habonim Welding Instructions" bulletin.

5.3 Weld End Valves

- 5.3.1 Valves must be disassembled before welding in line.
- 5.3.2 Welding of valves shall be performed by a qualified person according to the ASME Boiler Construction Code Section IX. For valves to be welded within the EEA, refer to the requirements of ESR 3.1.2 of the Pressure Equipment Directive 97/23/EC.
Bring the valve handle to the open position. **Warning:** trying to remove the valve body from the line in the closed position will damage the ball.
- 5.3.3 With the valve in the open position, loosen all body bolts. Fire-safe valves have screwed to the valve body.
- 5.3.4 Remove all but one body bolt, so the valve body can swing away from its installed position and be brought out of the pipe line. Fire-safe valves should have 2 opposing bolts remaining in the body.
- 5.3.5 If it is required to completely remove the body, remove the last bolt and bring out the body center section.
- 5.3.6 Swing out the body from between the end connectors.
- 5.3.7 Fire-safe valve end connectors are interlocked to the body (see **figure 3**). To overcome this feature it is necessary to separate the ends from the body using a block of wood or plastic mallet and swing the body out of the line. If the pipe does not allow enough movement, remove the remaining bolts and rotate the body through its port axis, enabling easier access to the end connectors flanges.
- 5.3.8 Remove and discard of the O-ring body seals.
- 5.3.9 Support the ball to prevent it from falling out of body and turn handle to the closed position for its removal. Set the ball aside in clean secure area for reuse.
- 5.3.10 **Do not scratch or cut the seats and sealing surfaces of the valves as this will cause valve leakage.**
- 5.4.11 Assemble the valve without the ball and seats. It is recommended to remove the valve wrench during the welding procedure.
- 5.4.12 Protect or remove actuators from weld splatter or arc strikes. Valves in the "Fail Close" position should be cycled to the open position.
- 5.3.13 Align valve to pipe line, ensuring proper fit to minimize pipe load. Tack weld only.
- 5.3.14 Complete welding in small segments. Allow enough time for cooling between each segment.
- 5.3.15 After completing the welds, wait for the valve to cool below 90°C (200°F).

- 5.3.16 After the valve cools down, follow again steps 2 to 9 of the DISASSEMBLY and section 7 to 13 of the ASSEMBLY.

6. MAINTENANCE

HABONIM valves have a long and trouble free life, and maintenance is seldom required. When maintenance is necessary, valves can be refurbished on site.

To extend valve performance and reduce possible plant problems, the following procedures should be followed:

- 6.1 If leakage at the stem is noted, tighten the gland nut about a 1/4-turn as a routine maintenance procedure. This will compensate for any wear or settling of the gland packing.
- 6.2 **Caution:** Excessive tightening of the stem nut can result in accelerated seal wear and high valve operating torque.
- 6.3 If the valve is removed from the line and disassembled, replacement of all seats and seals is recommended using the appropriate Habonim Repair kit. Examine all metallic sealing surfaces such as ball, stem, and the surfaces on the end connectors that contact the seats for wear, corrosion or damage.
- 6.4 Only Habonim's authorized spare parts should be used. Repair kits from Habonim consist of the following:
 - 2 x seat ring
 - 2 or 3 x gland packing
 - 1 x stem thrust ring
 - 2 x body seals
- 6.5 In addition to repair kits, other spare parts available from Habonim are: valve balls, stems, glands, bolts, screws and nuts. Should additional parts be required, it is recommended that the complete valve be replaced.
- 6.6 When ordering repair kits, please provide the valve size and full figure number code and series.

7. DISASSEMBLY

The following instructions are for in-line disassembly of valves sizes 1/2" to 2" (or 1 1/2" full bore).

- 7.1 Cycle the valve with the line pressure fully relieved before attempting to remove the valve from the pipeline, to insure pressure has also been discharged from the valve cavity.
- 7.2 Bring the valve handle to the open position. **Warning:** trying to remove the valve body from the line in the closed position will damage the ball.
- 7.3 With the valve in the open position, loosen all the body bolts and nuts. Fire-safe valves have bolts on each side screwed to the valve body.
- 7.4 Remove all but one body bolt, so the valve body can swing away from its installed position and be brought out of the pipe line. Fire-safe valves should have 2 opposing bolts remaining in the body.
- 7.5 If it is required to completely remove the body, remove the last bolt and bring out the body center section.
- 7.6 Swing out the body from between the end connectors.
- 7.7 Fire-safe valve end connectors are interlocked to the body (see **figure 3**). To overcome this feature it is necessary to separate

the ends from the body using a block of wood or plastic mallet and swing the body out of the line. If the pipe does not allow enough movement, remove the remaining bolts and rotate the body through its port axis, enabling easier access to the end connectors flanges.

- 7.8 Remove and discard the seat rings and body seals. Be careful not to damage the sealing surfaces.
- 7.9 Support the ball to prevent it from falling out of body and turn handle to the closed position for its removal. Set the ball aside in clean secure area for reuse.
- 7.10 Remove the wrench nut, serrated washer, handle, locking clip, gland nut, disk springs and gland. Place all components removed, in clean secure area.
- 7.11 Push the stem down into the body and remove it. Discard the stem thrust ring and packing, care taken not to scratch or nick the packing bore area of the body. Clean the stem and packing bore area.

The following instructions are for in-line disassembly of valves sizes 2 1/2" to 6".

- 7.12 Cycle the valve with the line pressure fully relieved before attempting to remove the valve from the pipeline, to insure pressure has also been discharged from the valve cavity.
- 7.13 Bring the valve handle to the open position. **Warning:** trying to remove the valve body from the line in the closed position will damage the ball.
- 7.14 With the valve in the open position, loosen all body bolts.
- 7.15 Remove all body bolts and bring out the body center section.
- 7.16 Locate the side of the body that has the seat retaining ring. Support the ball from that side to prevent it from falling out of body and turn handle to the closed position for its removal. Set the ball and seat retaining ring aside in clean secure area for reuse. Remove and discard the seat rings and body seals. Be careful not to damage the sealing surfaces.
- 7.17 Remove the wrench bolt, wrench head and handle, gland nut, stop plate and gland. Place all components removed, in clean secure area.
- 7.18 Push the stem down into the body and remove it. Discard the stem thrust ring and packing, care taken not to scratch or nick the packing bore area of the body. Clean the stem and packing bore area.

8. ASSEMBLY

The following instructions are for in-line assembly of valves sizes 1/2" to 2" (or 1 1/2" full bore).

- 8.1 Lubricate the new stem thrust ring and packing, with appropriate lubricant (Molycote 33 - thin smear). Place the stem thrust ring on the stem.
- 8.2 Insert the stem horizontally into the center body with the threaded side first and carefully guide it up through the stem bore.
- 8.3 Holding the stem up insert the new packing over the stem and into the stem bore. Place the gland and two disk springs onto the stem. The first spring concave side down and the second

spring concave side up.

- 8.4 Thread the gland nut onto the stem. Tighten the gland nut to the torque figures (**table 1**).
- 8.5 Place the locking clip on the gland nut by adjusting the orientation of the nut (in the clockwise direction).
- 8.6 Place the handle, serrated washer and thread the wrench nut on the stem. Holding the handle tighten the wrench nut tight.
- 8.7 Bring the handle to the closed position to insert the ball.
- 8.8 Place the ball in the center body until the stem tang is engaged and bring the valve to the open position to prevent the ball from falling out.
- 8.9 Place the new body seals and new seat rings in the body.
- 8.10 Ease back the body assembly between end connectors, taking care not to score faces or damage seals, and reinstall body bolts and nuts.
- 8.11 To prevent galling of threads of bolts or nuts, lubricate threads with an anti-galling compound.
- 8.12 Tighten the body bolts to the torque figures (**table 2 or 3**), and according to tightening pattern illustrated in **figure 1**.
- 8.13 Leave the valve in the open position for flushing the line.

The following instructions are for in-line assembly of valves sizes 2 1/2" to 6".

- 8.14 Lubricate the new stem thrust ring and packing, with appropriate lubricant (Molycote 33 - thin smear). Place the stem thrust ring on the stem.
- 8.15 Insert the stem horizontally into the center body with the threaded side first and carefully guide it up through the stem bore.
- 8.16 Holding the stem up insert the new packing over the stem and into the stem bore. Place the gland and stop plate onto the stem.
- 8.17 Thread the slotted gland nut onto the stem. Tighten the gland nut to the torque figures (**table 1**).
- 8.18 Place the wrench head on the stem making sure it is parallel to the stem groove for ball valve position. Insert the handle through the wrench head and tighten with the wrench bolt.
- 8.19 Bring the handle to the closed position to insert the ball.
- 8.20 Place the ball in the center body until the stem tang is engaged and bring the valve to the open position to prevent the ball from falling out.
- 8.21 Place the new body seat rings, seat retaining ring and new body seals in the body.
- 8.22 Ease back the body assembly between end connectors, taking care not to score faces or damage seals, and reinstall body bolts and nuts.
- 8.23 To prevent galling of threads of the bolts, lubricate threads with an anti-galling compound.
- 8.24 Tighten the body bolts to the torque figures (**table 2 or 3**), and according to tightening sequence illustrated in **figure 1**.
- 8.25 Leave the valve in the open position for flushing the line.

TABLE 1
Gland Nut Tightening Torque

Reduce Bore	Full Bore	Nut Thread	* PTFE Seals		** Graphite Seals	
			Nm	in.lb	Nm	in.lb
1/2"		3/8"-24 UNF	4	35	4 - 6	35 - 53
3/4"	1/2"	3/8"-24 UNF	4	35	4 - 6	35 - 53
1	3/4"	7/16"-20 UNF	9	80	9 - 11	80 - 97
1 1/4"	1	7/16"-20 UNF	9	80	9 - 11	80 - 97
1 1/2"	1 1/4"	9/16"-18 UNF	13	115	13 - 16	115 - 140
2"	1 1/2"	9/16"-18 UNF	13	115	13 - 16	115 - 140
2 1/2"	2"	M20 x 2.5	30	265	30 - 36	265 - 320
3"	2 1/2"	1" - 14 UNS	60	530	60 - 72	530 - 637
4"	3"	1" - 14 UNS	60	530	60 - 72	530 - 637
6"	4"	1 1/2" - 12 UNF	120	1060	120 - 145	1060-1280

* These torque figures are applicable on PTFE carbon filled stem.
 ** Graphite stem seals must be torqued to the higher torque figure in the table, then cycled 6-10 times and re-torqued to the lower torque figure.

IMPORTANT:

An excessively tightened gland nut can cause excessive packing wear and increase stem torque.

BODY BOLTS

H23 series valves sizes 1/2"-2" bolts are threaded into the body. All sizes carry 6 bolts, 3 to each side of the body. Firesafe type valves AFH23 carry the same bolt size and the same number of bolts. All the H23 body bolt threads are imperial unless stated different.

H27 series non-firesafe valves sizes 1/2"-2" have through bolts and nuts. Sizes 1/2"-1 1/4" carry 6 bolts and nuts. Sizes 1 1/2" - 2" carry 8 bolts and nuts. Firesafe type valves AFH27 bolts are threaded into the body.

H27 series firesafe and non-firesafe valve sizes 2 1/2"-6" bolts are threaded into the body. Sizes 2 1/2" - 4" carry 16 bolts. Size 6" carry 28 bolts. All the bolts are metric.

TABLE 2
H27 & AFH27 Body Bolt Tightening Torque

Reduce Bore	Full Bore	Bolt Thread	Carbon Steel		Stainless Steel	
			Nm	in.lb	Nm	in.lb
1/2"		M8	25	220	30	265
3/4"	1/2"	M8	25	220	30	265
1	3/4"	M10	48	425	65	575
1 1/4"	1	M10	48	425	65	575
1 1/2"	1 1/4"	M12	83	735	100	885
2"	1 1/2"	M12	83	735	100	885
2 1/2"	2"	M16	200	1770	245	2170
3"	2 1/2"	M16	200	1770	245	2170
4"	3"	M20	390	3450	490	4340
6"	4"	M20	390	3450	490	4340

TABLE 3
H23 & AFH23 Body Bolt Tightening Torque

Reduce Bore	Full Bore	Bolt Thread	Carbon Steel		Stainless Steel	
			Nm	in.lb	Nm	in.lb
1/2"		5/16"-18 UNC	18	160	18	160
3/4"	1/2"	5/16"-18 UNC	18	160	18	160
1	3/4"	3/8"-16 UNC	39	345	39	345
1 1/4"	1	3/8"-16 UNC	39	345	39	345
1 1/2"	1 1/4"	7/16"-14 UNC	65	575	65	575
2"	1 1/2"	7/16"-14 UNC	65	575	65	575

FIGURE 1
Body Bolt Tightening Pattern

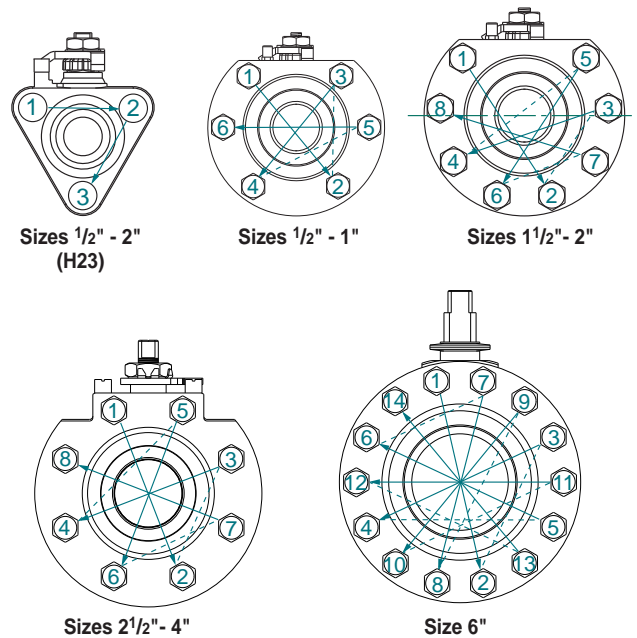

FIGURE 2
Valve Marking and Labeling

All valves marking is on a nameplate which is spot welded to the valve body. Valves for the European market and above 1" carry the CE mark with the information required by the PED.

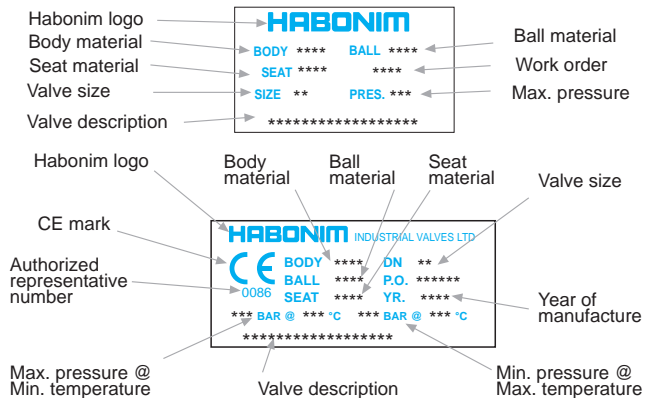
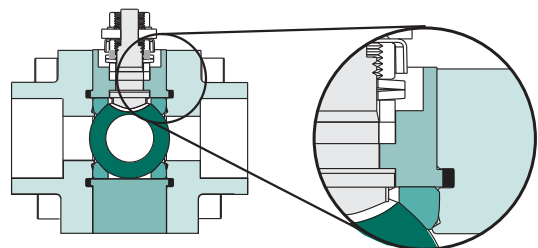

FIGURE 3
Fire-safe valve body and interlocked end connector



Habonim reserves the right to change design features without prior notice.

DELTRIN® is a registered trademark of DuPont.

H23 SERIES VALVE SIZES: 1/2" - 2"

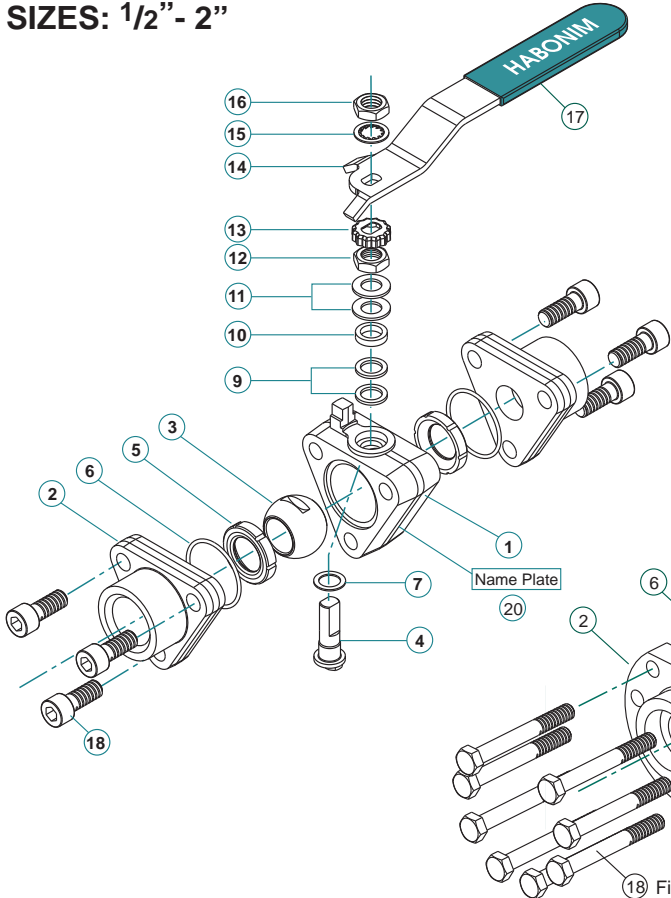

H27 SERIES VALVE SIZES: 1/2" - 2 1/2"

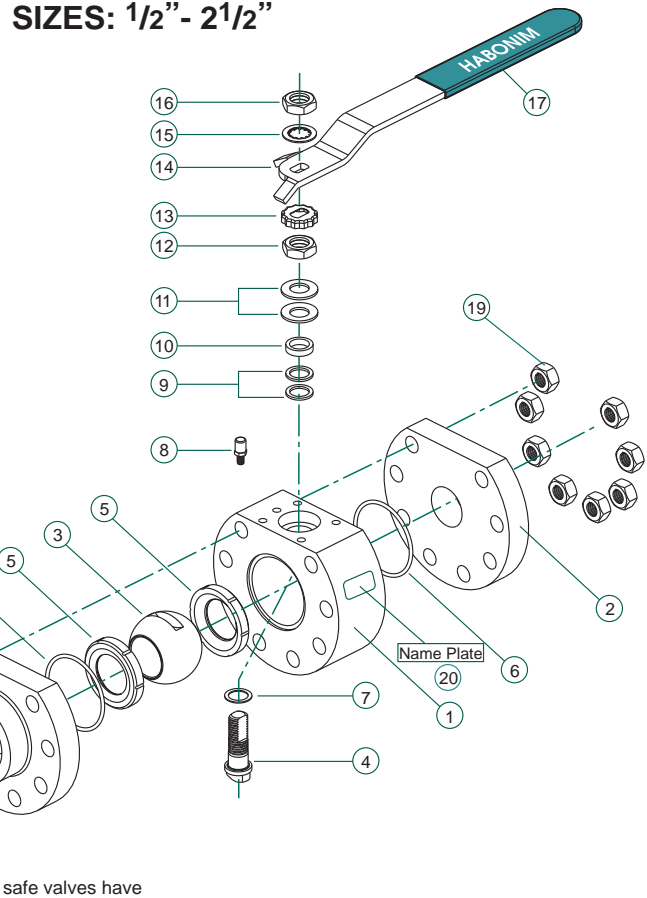

Material Specification

ITEM	DESCRIPTION	MATERIAL	QTY.
1	BODY	STAINLESS ST. AISI 316L CARBON ST. ASTM A105	1
2	END CONNECTOR	STAINLESS ST. AISI 316L CARBON ST. ASTM A105	2
3	BALL	STAINLESS ST. ASTM316, CF8M STAINLESS ST. 17-4PH (1/2"-3/4")	1
4	STEM	STAINLESS ST. 17-4PH	1
*5	SEAT	DELRIN® PEEK (VIRGIN), VESPEL	2
*6	BODY SEAL	NBR O-RING SH-90 GRAPHITE (FIRESAFE)	2
*7	STEM THRUST SEAL	NYLATRON, PEEK	1
8	STOP PIN	STAINLESS ST. AISI 304	1
*9	STEM PACKING	PTFE CARBON FILLED, O-RINGS GRAPHITE (FIRESAFE)	2-3
10	GLAND	STAINLESS ST. AISI 304	1-2

ITEM	DESCRIPTION	MATERIAL	QTY.
11	DISC SPRING	STAINLESS ST. 17-7PH	2
12	GLAND NUT	STAINLESS ST. AISI 316 CARBON ST. ZINC PLATED	1
13	TAB WASHER	STAINLESS ST. AISI 316	1
14	WRENCH	STAINLESS ST. AISI 430 CARBON ST. ZINC PLATED	1
15	SERRATED WASHER	STAINLESS ST. AISI 316	1
16	WRENCH NUT	STAINLESS ST. AISI 316 CARBON ST. ZINC PLATED	1
17	SLEEVE	VINYL PLASTISOL	1
18	BODY BOLT	STAINLESS ST. AISI 304	6 (H23) 6-8 (H27)
19	BODY NUT	STAINLESS ST. AISI 316 CARBON ST. ZINC PLATED	6 (H23) 6-8 (H27)
20	NAME PLATE	STAINLESS ST.	1

* STANDARD ITEMS FOR REPAIR KITS